

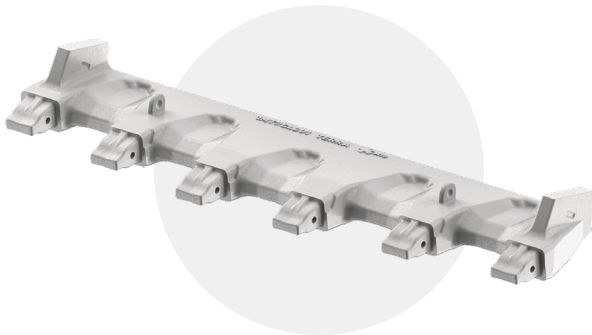

CAST LIP SOLUTIONS FOR MINING EXCAVATORS



Cast Lips 148" - 201"
for mining excavators of 450 - 1.000 t

The most advanced cast lip option for excavators of >450 t and for increased productivity in heavy-mining applications.

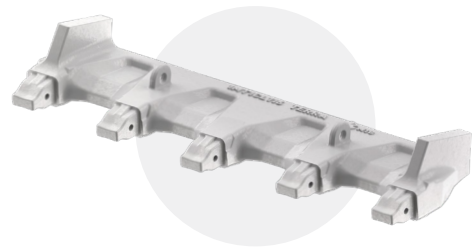

Cast Lips 116" - 144"
for mining excavators of 250 - 400 t

Smaller sizes of the field-proven TERRA series are an alternative to plate lip G.E.T. solutions.

Benefits and Features



HIGHER PRODUCTIVITY

TERRA's **slim design** along with the self-sharpening design of its equipment, guarantee a steady penetration along their wear life.



REDUCED OPERATIONAL COSTS

The **optimized design** allows better distribution of the wear material. As a result, the **weight reduction** provides proven fuel and cost savings.



LONGER OPERATIONAL TIME

Large contact areas and **smooth transitions** for lip shrouds reduce plastic deformation at critical areas, preventing the generation of cracks.



SHORT DOWNTIMES

TERRA's critical areas are optimally protected by MTG's **specific G.E.T.** to increase the cast lip's wear life thus reducing rebuild needs.

Full Bucket Wear Packages

TERRA + TWINMET + PROMET



Heavy-Duty Option



Penetration Option



The combination of the robust TWINMET 3-part tooth system and PROMET lip shrouds offers an efficient and optimum wear protection. Depending on your requirements, the G.E.T. package can be optimized for penetration or heavy-duty applications.

The 2-part TWINMET tooth system and PROMET shrouds complement the smaller cast lip sizes to offer optimal bucket penetration. For more abrasive applications, an optional wear cap provides additional protection.

TERRA Range Overview

SIZE	INSIDE BUCKET WIDTH	REFERENCE	NUMBER OF POSITIONS	MACHINE CATEGORY	MACHINE EXAMPLES
TM1	116" / 2.950 mm	1MT1CL116 TERRA	5	250-400 t	
TM1	122" / 3.100 mm	1MT1CL122 TERRA	5	250-400 t	
TM1	136" / 3.450 mm	1MT1CL136 TERRA	5	250-400 t	HITACHI* EX3600 (FS) KOMATSU* PC4000 (FS) CATERPILLAR* 6040 (BH/FS)
TM1	140" / 3.560 mm	1MT1CL140 TERRA	6	250-400 t	
TM1	144" / 3.650 mm	1MT1CL144 TERRA	6	250-400 t	
TM5/4 TM5/6	148" / 3.760 mm	1MT5CL148 TERRA	5	450-700 t	
TM5/4 TM5/6	163" / 4.150 mm	1MT5CL163 TERRA	5	450-700 t	HITACHI* EX5600-6 (BH) KOMATSU* PC5500-6 (BH) CATERPILLAR* 6050 / 6060 (FS)
TM5/4 TM5/6	169" / 4.300 mm	1MT5CL169 TERRA	6	450-700 t	KOMATSU* PC7000 (FS)
TM5/4 TM5/6	185" / 4.700 mm	1MT5CL185 TERRA	6	450-700 t	
TM5/4 TM5/6	201" / 5.100 mm	1MT5CL201 TERRA	6	450-700 t	
TM7/4 TM7/6	169" / 4.300 mm	1MT7CL169 TERRA	5	650-1.000 t	HITACHI* EX8000-6 (BH/FS) KOMATSU* PC8000 (BH/FS) CATERPILLAR* 6090 (FS)
TM7/4 TM7/6	201" / 5.100 mm	1MT7CL201 TERRA	6	650-1.000 t	

*The brands identified with an asterisk do not belong to METALOGENIA S.A. and this organization refers to them only to identify the destination of its products, without there being any relationship between METALOGENIA S.A. and the legitimate owners of any such brands.

MTG HEADQUARTERS

MTG NORTH AMERICA

MTG AUSTRALIA

MTG Quality Certificates